

# Preserved Green Wall Technical Specifications

---

## PRODUCT SPECIFICATION SHEET

Overview

Product Composition

Panelization Options

Plant & Moss Selection

Styles

Performance

Wall Installation

Add-Ons Installation

Product Packaging



# PRESERVED GREEN WALL OVERVIEW

## **Modular & Maintenance-Free**

No watering, pruning, or sunlight required. Maintains a consistent appearance under standard interior conditions, making it suitable for long-term interior applications.

## **Prefabricated Panel System**

Factory-assembled panels with pre-installed plant units and sheet moss. Delivered ready for installation, reducing on-site labor and installation time.

## **Lightweight & Direct Installation**

Lightweight system (0.78 lbs/sqft). Weight based on installed condition including plant units and moss layer. Mounts directly to wall framing or structural blocking, eliminating the need for secondary support systems.

## **Replaceable Plant Units**

Individually secured plant units allow removal and replacement without disturbing adjacent units. Supports efficient long-term maintenance and localized repairs.

## **Sustainable Material System**

Constructed with recycled PET and preserved natural plant materials. May contribute to LEED v4 credits depending on project conditions.

# Preserved Green Wall

## Product Composition

### Preserved Greenery Module — Exploded View

The system consists of five integrated components.

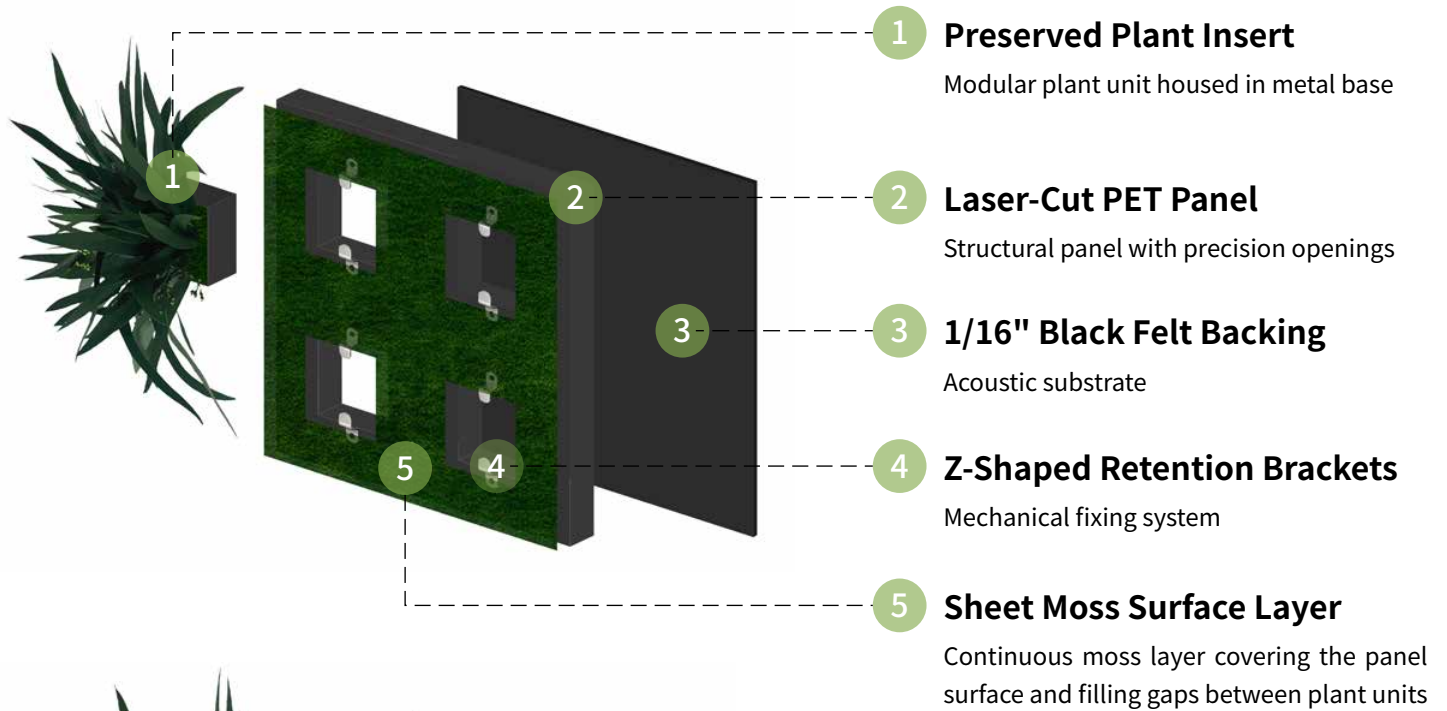

## PET Back Panel

The PET back panel is the base unit of the system.

Panel size: **12" × 12"** (1 sf).

Material: Recycled PET acoustic board.

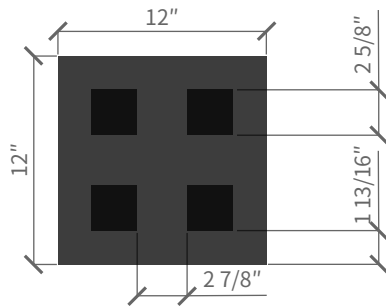

Forest Style

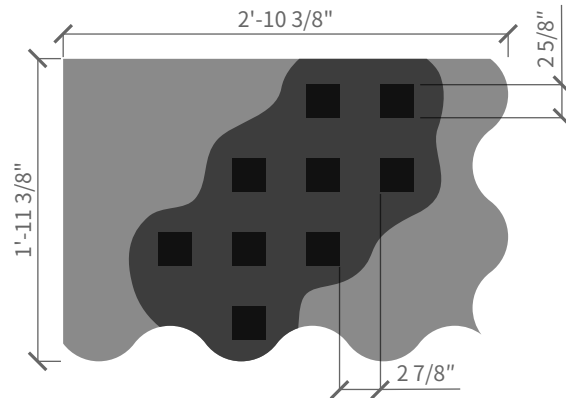

Lush Style (LS-A)

## Upright Plant Unit — Basic Module Example

The Upright Plant Unit is the standard vertical module used in main field areas. It fits within the standard panel opening. Standard layout: **4 units per 12" × 12" panel**.

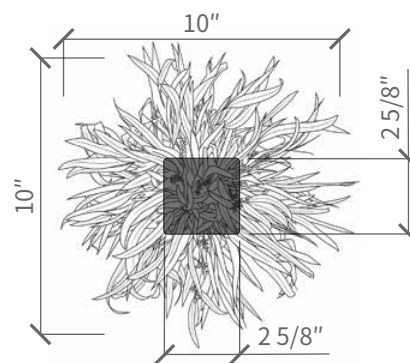
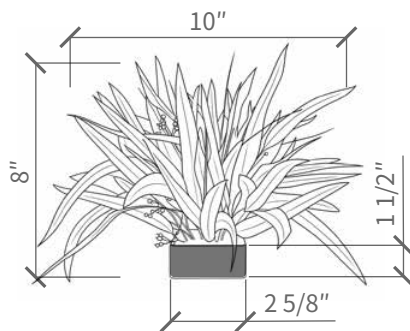

## Drape Plant Unit — Basic Module Example

The Drape Plant Unit is used at perimeter edges or transition zones within the wall. It shares the same base format as the Upright Plant Unit but introduces a trailing profile.

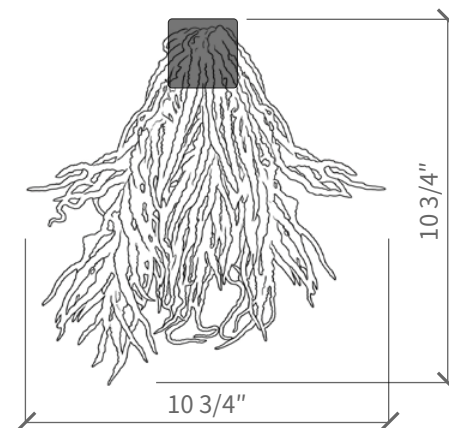
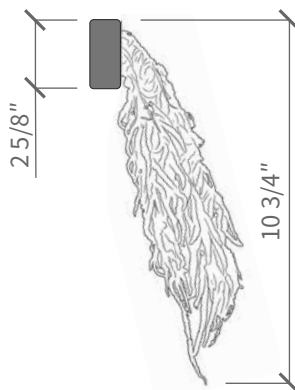

# Preserved Green Wall Panelization Options

The Preserved Green Wall system is based on a **12" × 12" (1' × 1')** panel module. Panels can be combined to form continuous wall surfaces of any size. Minimum installation size is one panel.

## Standard

Standard configuration uses repeating **12" × 12" panel modules**. Panels are factory-assembled and delivered ready for installation.

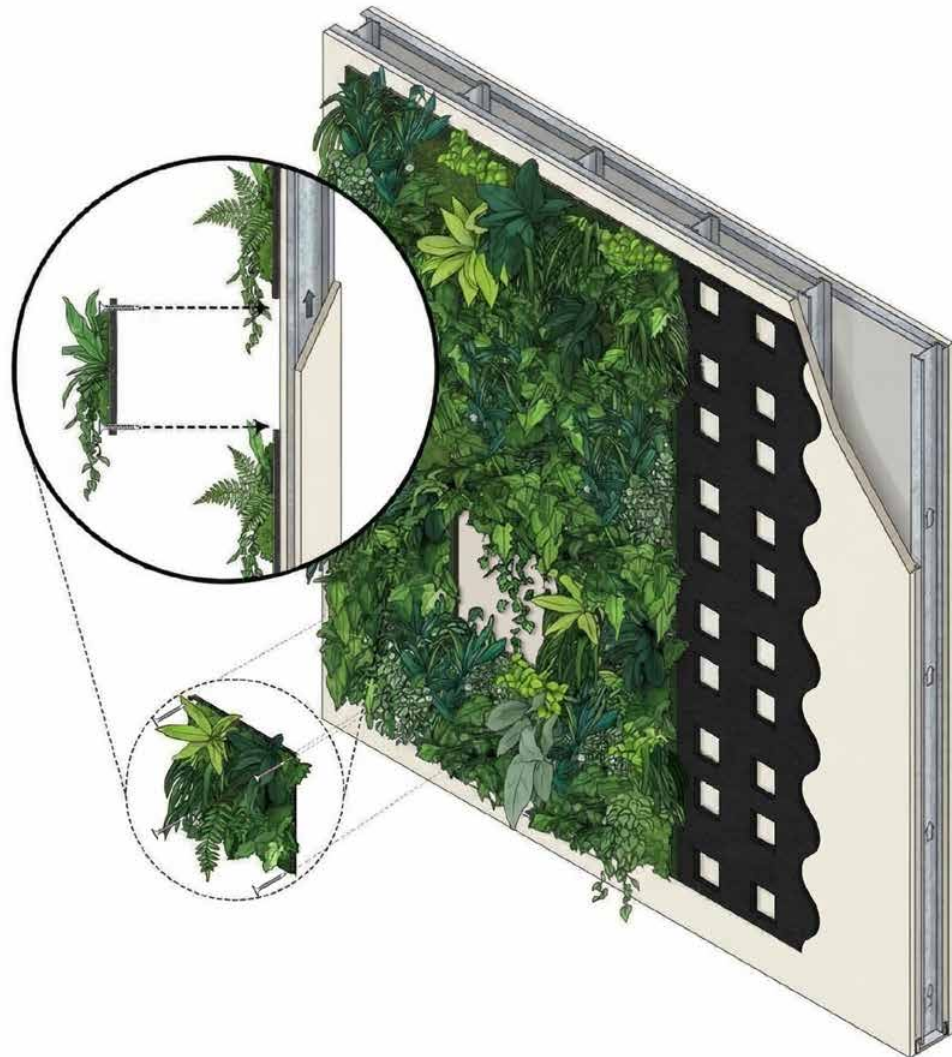

Multi-Panel Layout

# Custom Sizing

Panels are fabricated to project-specific dimensions based on the approved layout.

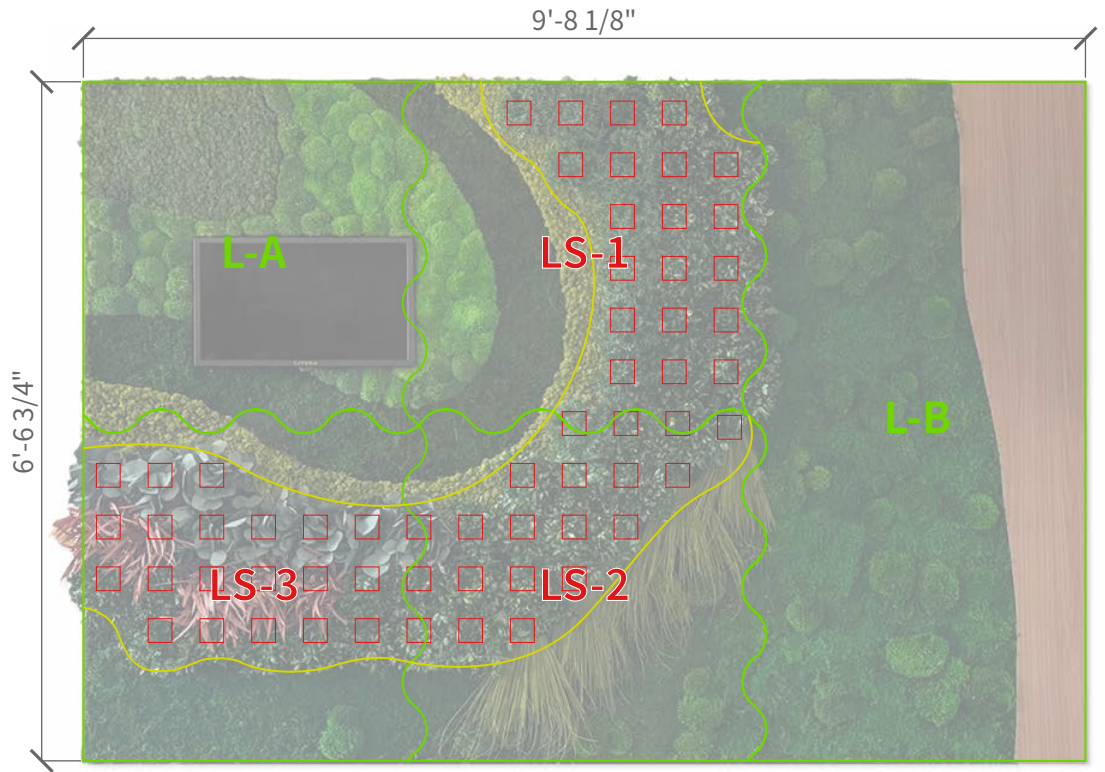

# Preserved Green Wall Plant & Moss Selection

## Upright Plant Species — Small Module — 11 Options

4 units per 12"×12" panel.



Silver Dollar Eucalyptus



Willow Eucalyptus



Parvifolia Eucalyptus



Japanese Andromeda



Osmanthus



Podocarpus Bush



Citrus Leaf



Grevillea Foliage



Gardenia Leaf



Peppergrass



Leatherleaf Fern

\* Canopy Height (8" ±1") + Canopy Width (10" ±1")

# Upright Plant Species — Large Module — 10 Options

1 unit per 12"×12" panel.



Silver Dollar Eucalyptus



Willow Eucalyptus



Parvifolia Eucalyptus



Ruscus Greenery

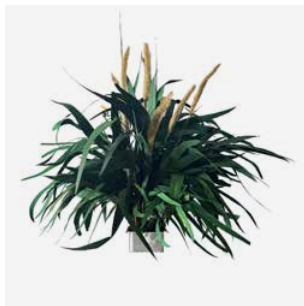

Foxtail Grass &  
Willow-leaf Eucalyptus



Osmanthus



Podocarpus Bush



Grevillea Foliage



Peppergrass



Leatherleaf Fern

## Drape Plant Species — 3 Options

Used at edges or as accent zones in combination with upright plant species.



Steel Grass



Asparagus Fern



Amaranthus

## Natural Accents — 3 Options

Placed freely per design, not by module.

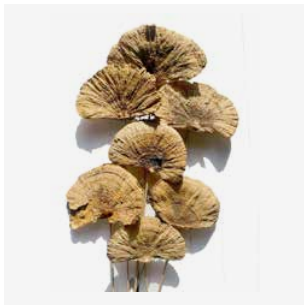

Mushroom



Bark

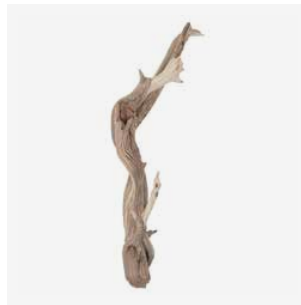

Driftwood

## Preserved Moss

Sheet moss is used as a continuous surface layer across panel surfaces and at plant unit boundaries. Available moss types include Bun Moss, Reindeer Moss, Sheet Moss, and Mood Moss.



Bun Moss



Reindeer Moss



Sheet Moss



Mood Moss

# Preserved Green Wall Styles

The Preserved Green Wall panel system supports **two configurations** based on plant coverage. Both use the same panel components and installation method.

## Lush Style

Sheet moss base layer with plant units placed at designated panel positions. Plant coverage ranges from **10–99%**, depending on design intent.

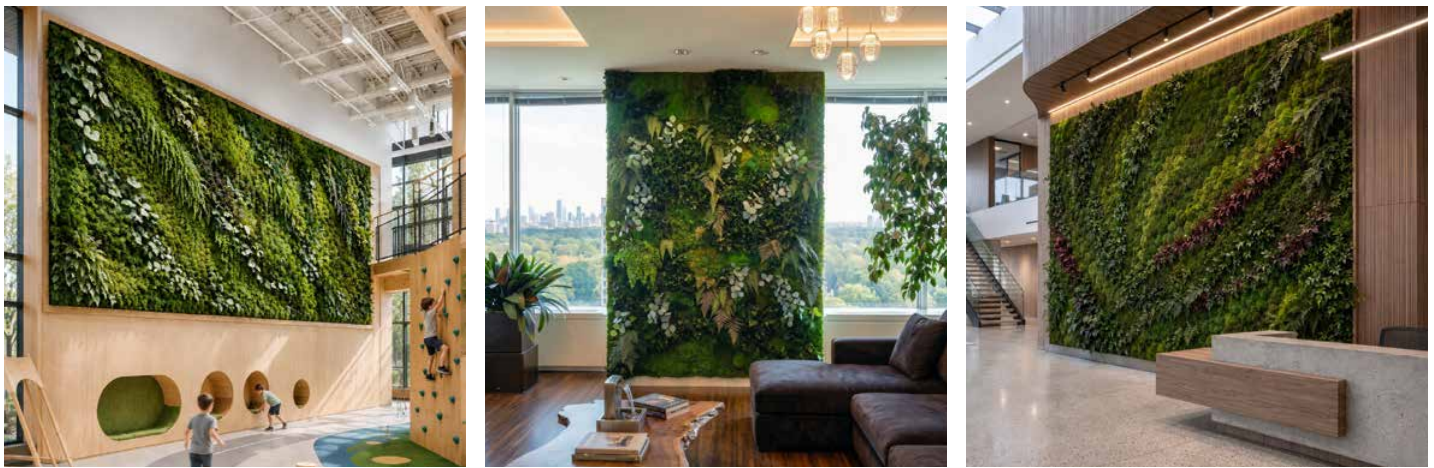

## Forest Style

**Full plant unit coverage** across the entire wall surface, with sheet moss filling gaps between plant units. Compatible with single-species or mixed-species layouts.



# Preserved Green Wall Performance



## Acoustic Performance

Tested in accordance with ASTM C423. Laboratory NRC: 1.01.

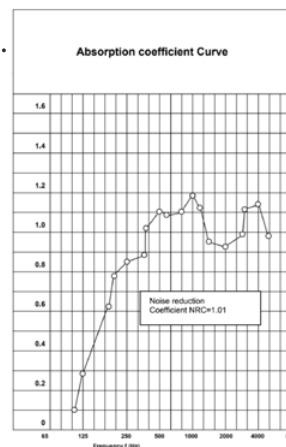

Frequency f/Hz	Absorption coefficient $\alpha$
100	0.20
125	0.28
160	0.52
200	0.68
250	0.85
315	0.88
400	1.02
500	1.10
630	1.08
800	1.10
1000	1.18
1250	1.12
1600	0.96
2000	0.92
2500	0.99
3150	1.12
4000	1.14
5000	0.98



## Fire Performance

Tested in accordance with ASTM E84. Class A rating; Flame Spread Index 15 / Smoke Developed Index 400.

*Fire performance applies to the system as tested. Individual components are not separately fire-rated.*



## Low VOC — CDPH v1.2 Compliant

Manufactured in alignment with CDPH v1.2 low-emitting material standards, supporting indoor air quality requirements and common green building certifications such as LEED v4 / WELL.



## UV Stability Tested

200h+ accelerated UV tested (approx. 8–10 years of indoor light exposure) — supports long-term visual stability across all moss types.



## Expected Service Life

8–10 years under standard interior environmental conditions.



## LEED v4 Credit Contributions (Potential)

The product contributes to the following LEED v4 credits, depending on project conditions and documentation.

- MRc4: Building Product Disclosure and Optimization – Material Ingredients
- MRc3: Building Product Disclosure and Optimization – Sourcing of Raw Materials
- MRc5: Construction and Demolition Waste Management
- MRc6: Construction and Demolition Waste Management Planning
- EQc9: Acoustic Performance
- INC1: LEED Pilot Credit
- INC2: LEED Pilot Credit



## 5-Year Limited Warranty

5-year limited warranty covering materials and workmanship under normal interior use. Warranty is void if the product is installed outdoors, exposed to direct moisture, or used outside the specified environmental conditions.

*Note: Natural variation in color, texture, and density inherent to preserved plant materials is not covered. Gradual aging and natural color shift over time are not considered warranty defects. Project acceptance standards shall be established based on an approved sample or mockup panel.*



## Care Instructions

- Indoor use only
- Avoid prolonged direct sunlight
- Maintain standard indoor humidity levels

*Note: For detailed guidance, refer to the Maintenance and Care Guide.*

# Preserved Green Wall Wall Installation

## Tool Required

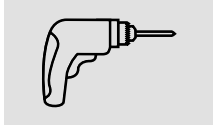

Cordless screwdriver

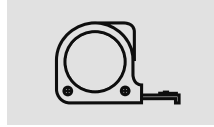

Measuring tape

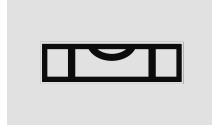

Building level



Triangle Ruler

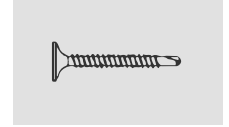

Screws

## Installation Steps

### 1. REFERENCE THE LAYOUT DRAWING

Refer to the supplied layout drawing. Each panel is labeled on the back with an alphanumeric code (e.g., L-A, S-4) corresponding to the layout. In Lush Style, plant unit zones are separately identified in the layout drawing (e.g., LS-A, LS-B).

### 2. ARRANGE PANELS BEFORE INSTALLATION

Lay out all panels per the layout drawing. Confirm sequence and zone assignment before beginning installation.

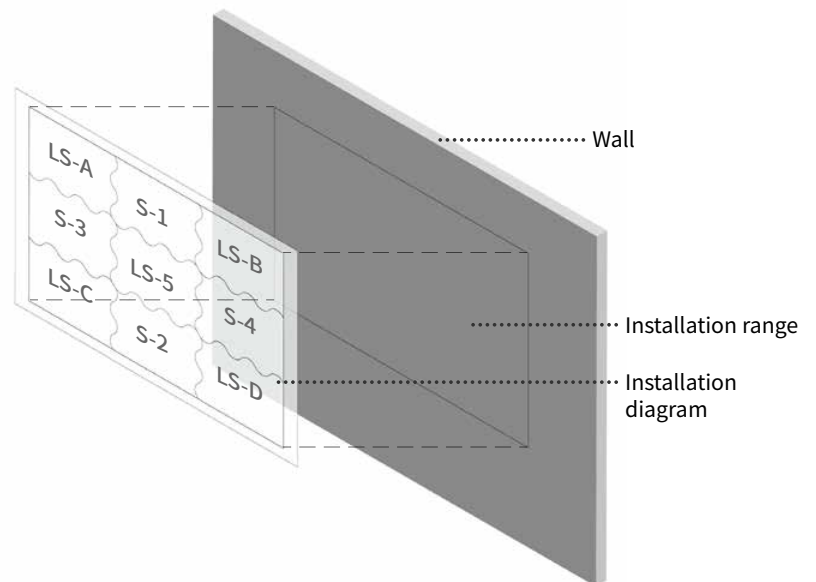

### 3. PREPARE AND MARK SURFACE

Using Panel A as the reference point, mark the installation area with a level and tape measure. Confirm the wall surface is clean, dry, and structurally sound. Recommended substrate flatness tolerance: 1/8" in 10'-0". Install blocking at fastening points where no framing member is present.

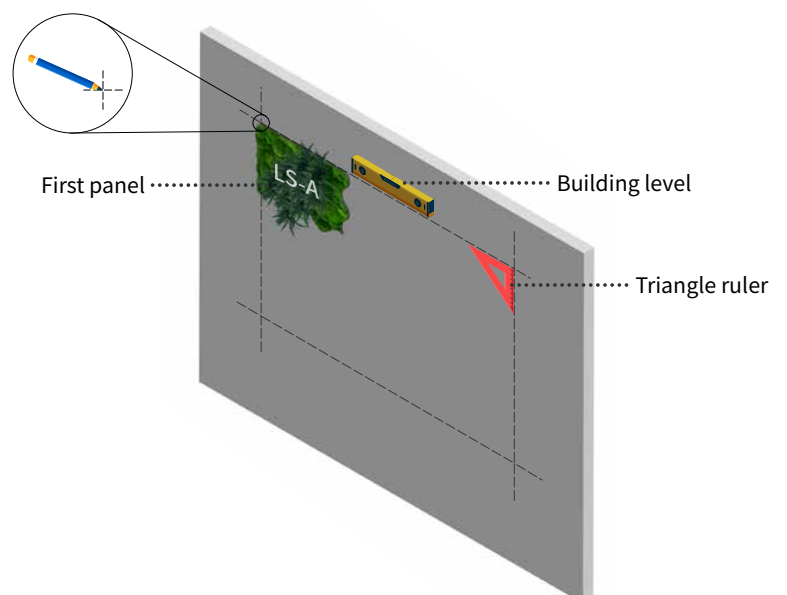

#### 4. ATTACH PANELS

Fasten panels using a screwdriver. All screws must engage wall framing or approved structural blocking — gypsum board alone is not acceptable. Drive screws through the natural gaps between plant units to maintain a clean finished appearance. Maximum fastener spacing: 24".

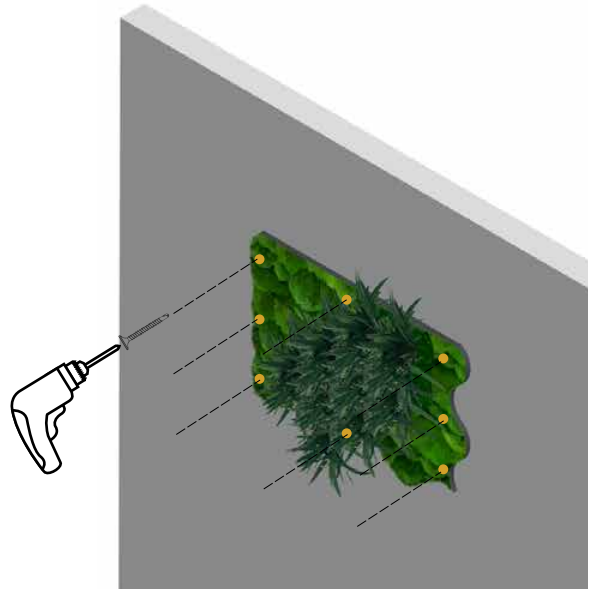

#### 5. ALIGN PANELS

Orient panels per the layout drawing. Lush Style wave-cut edges interlock precisely — no visible seam between plant zones and moss fields. Forest Style straight edges align flush, producing a uniform grid pattern.

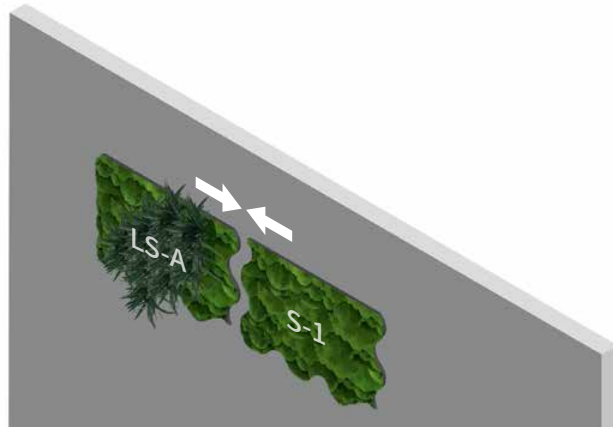

#### 6. FINAL INSPECTION

Inspect the completed installation from multiple angles. Confirm all panels are properly aligned and securely fastened. Verify all LS-designated plant unit zones are correctly populated.

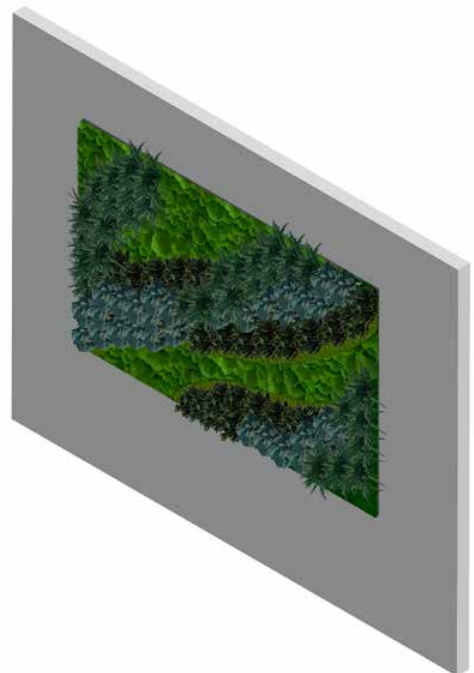

# Plant Unit Replacement

The system allows individual plant units to be replaced without panel removal or disturbance to adjacent units.

## Step 1 — Locate

Locate the target unit using the layout drawing and unit numbering.

## Step 2 — Unlock

Rotate the two Z-shaped retention brackets on the plant unit base to the release position.

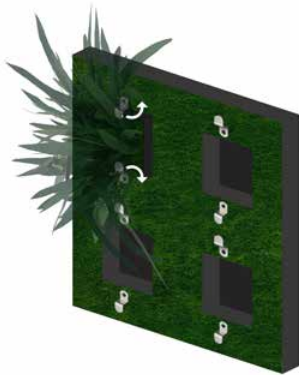

## Step 3 — Remove

Pull the plant unit outward.

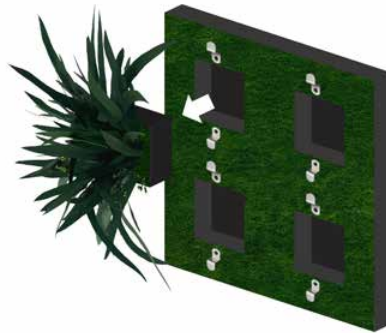

## Step 4 — Insert

Insert the corresponding plant unit into the panel opening. Align the base orientation and push inward until fully seated.

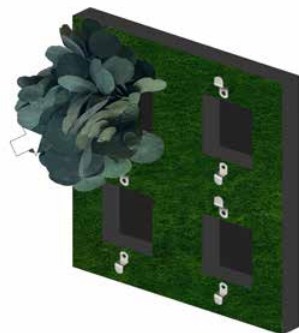

## Step 5 — Lock

Rotate the retention brackets back to the locked position. Use a Phillips screwdriver to tighten the brackets until they can no longer rotate. Pull gently to confirm a secure fit.

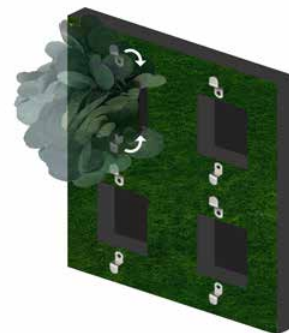

## Step 6 — Inspect

Confirm the new unit aligns visually with surrounding units. If adjustment is required, unlock, reposition, and re-lock.

# Preserved Green Wall

## Add-Ons Installation

Add-on components are factory-installed unless otherwise specified. Refer to the **Add-On Technical Specifications** and Field Connection & Edge Detail Drawings for project-specific requirements.

### Custom Logo



PVC / Acrylic



Stainless Steel



Wooden

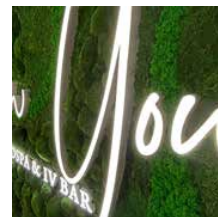

Illuminated

### High-Quality Aluminum Alloy Frame



Black



White



Silver



Titanium Gold



Rose Gold



White Oak Grain



Dark Walnut Grain



Teak Wood Grain

# Preserved Green Wall Product Packaging

## Panel Packaging

Panels are packaged in rigid wooden crates to protect against damage during transit.



Wooden crates

## Plant Unit Packaging

Plant units are pre-installed and secured during transit to prevent movement.

## Replacement Plant Units Included

Each order includes a set of spare plant units for future replacement. Species and quantity match the project order.

*Note: To order additional replacement units, contact Wildleaf LLC — [contact@wildleaf.design](mailto:contact@wildleaf.design).*